

ESP312X-10D

25Gb/s SFP28 LR 10km DDM Transceiver



PRODUCT FEATURES

- Support data rate up to 25.78125Gb/s
- Hot-Pluggable SFP Footprint and Single LC Connector
- Up to 10km reach for G.652 SMF
- 1310nm DFB laser and PIN receiver
- Temperature Range:
 - Commercial:0°C ~70°C
 - Industrial: -40°C ~85°C
- Power consumption
 - Commercial:1.0W
 - Industrial:1.2W
- RoHS 6 compliance
- Compliant to IEEE 802.3cc, SFF-8472 and SFF-8419
- Complies with EU Directive 2015/863/EU

APPLICATIONS

- 25GBASE-LR Ethernet
- CPRI option 10

DESCRIPTIONS

The ESP312X-10D(I) is a single-Channel, Pluggable, Fiber-Optic SFP28 for 25 Gigabit Ethernet and Infiniband EDR Applications. It is a high performance module for short-range data communication and interconnect applications which operate at 25.78125 Gbps up to 10km. They are compliant with SFF-8431,SFF-8432. The transmitter converts serial CML electrical data into serial optical data. The receiver converts serial optical data into serial CML electrical data.Digital diagnostics functions are available via a 2-wire serial interface, as specified in SFF-8472.

Ordering Information

Part No.	Data Rate (optical)	Laser	Fiber Type	Distance	Optical Interface	Temp	DDMI	Latch Color
ESP312X-10D	25.78125Gbps	DFB	SMF	10km	LC	0~70°C	Y	Blue
ESP312X-10DI	25.78125Gbps	DFB	SMF	10km	LC	-40~85°C	Y	Blue

I.Absolute Maximum Ratings

Parameter	Symbol	Min.	Typical	Max.	Unit	Notes
Storage Temperature	T_{stg}	-40		+85	°C	
Case Operating Temperature(Commercial)	T_o	0		70	°C	
Case Operating Temperature (Industrial)	T_o	-40		85	°C	
Relative Humidity - Storage	R_{HS}	5		95	%	
Relative Humidity - Operating	R_{HO}	5		85	%	
DC Supply Voltage	V_{CC}	0		3.6	V	

II.Recommended Operating Conditions

Parameter	Symbol	Min.	Typical	Max.	Unit	Notes
Case Operating Temperature	Top	0	-	70	°C	Commercial
		-40		85		Industrial
Power Supply Voltage	V_{CC}	3.13	3.3	3.47	V	
Transmission Distance	TD	-	-	10	km	Over SMF

III. Electrical Characteristics

High-Speed Signal: Compliant to CEI-25G-VSR

Low-Speed Signal: Compliant to SFF-8419

Parameter	Symbol	Min.	Typical	Max.	Unit	Notes	
Transmitter (Module Input)							
Differential Input Resistance	$R_{R_{din}}$	90	100	110	Ω		
Input Differential Voltage	$R_{V_{diff}}$	-	-	900	mVpp		
Tx_Disable	Normal Operation	V_{IL}	-0.3	-	0.8	V	
	Laser Disable	V_{IH}	2.0	-	$V_{CC}+0.3$	V	
Receiver (Module Output)							
Differential Resistance	T_{R_d}	90	100	110	Ohm		
Output Differential Voltage	$T_{V_{diff}}$	-	-	900	mVpp		
Differential Termination Resistance Mismatch	$T_{R_{dm}}$	-	-	10	%		
Rx los	Normal Operation	V_{OL}	-0.3	-	0.4	V	
	Loss Signal	V_{OH}	2	-	V_{CCHOST}	V	

IV. Optical and Characteristics

Parameter	Symbol	Min.	Typical	Max.	Unit	Notes
Transmitter						
Optical Modulation Amplitude(OMA)	POMA	-4		2.2	dBm	
Average Output Power	POUT	-7		2	dBm	
Average Output Power(Laser Off)	POFF			-30	dBm	
Wavelength	λ	1295		1325	nm	
Spectrum Bandwidth @ -20dB	$\Delta\lambda$			1	nm	
Side mode suppression ratio(SMSR)	SMSR	30			dB	
Extinction ratio	ER	3.5			dB	
Transmitter and dispersion penalty (TDP)				2.7	dB	
RIN_{20OMA}	RIN			-130	dB/Hz	
Receiver						
Wavelength	λ	1295		1325	nm	
Received Sensitivity(OMA)	$P_{SEN-OMA}$			-13.3	dBm	1
Stressed receiver sensitivity (OMA)	$R_{SEN-OMA-stress}$	-	-	-9.5	dBm	1
Optical Power Overload	$P_{IN(SAT)}$	2			dBm	
Damage threshold		3			dBm	2

Optical Communications Products Alliance

Receiver Reflectance	RFL			-26	dB	
Rx_LOS of Signal Assert	P _A	-30			dBm	
Rx_LOS of Signal De-assert	P _D			-17	dBm	
Rx_LOS of Signal Hysteresis	P _{Hy}	0.5		5	dB	
Optical Return Loss Tolerance	ORLT	20			dB	

Notes:

1. Test pattern: PRBS31. BER<5x10⁻⁵;
2. The receiver shall be able to tolerate, without damage, continuous exposure to an optical input signal having this average power level. The receiver does not have to operate correctly at this input power.

V.Digital Diagnostics

Parameter	Range	Accuracy	Unit	Calibration
Temperature	-40 to 85	±3	°C	Internal
Voltage	3.13 to 3.47	±3%	V	Internal
Tx Bias Current	0 to 100	±10%	mA	Internal
Tx Output Power	-7 to 2	±3	dB	Internal
Rx Input Power	-17 to 2	±3	dB	Internal

VI.Communication Interface Timing Characteristics

Parameter	Symbol	Min.	Typical	Max.	Unit	Notes
TX_Disable Assert Time	t _{off}			100	us	
TX_Disable Negate Time	t _{on}			2	ms	
Time to Initialize Include Reset of TX_FAULT	t _{int}			300	ms	
TX_FAULT from Fault to Assertion	t _{fault}			100	us	
TX_Disable Time to Start Reset	t _{reset}	10			us	
Receiver Loss of Signal Assert Time	T _{A,RX_LOS}			100	us	
Receiver Loss of Signal Deassert Time	T _{d,RX_LOS}			100	us	
Rate-Select Chage Time	t _{ratesel}			10	us	

VII.Pin Diagram

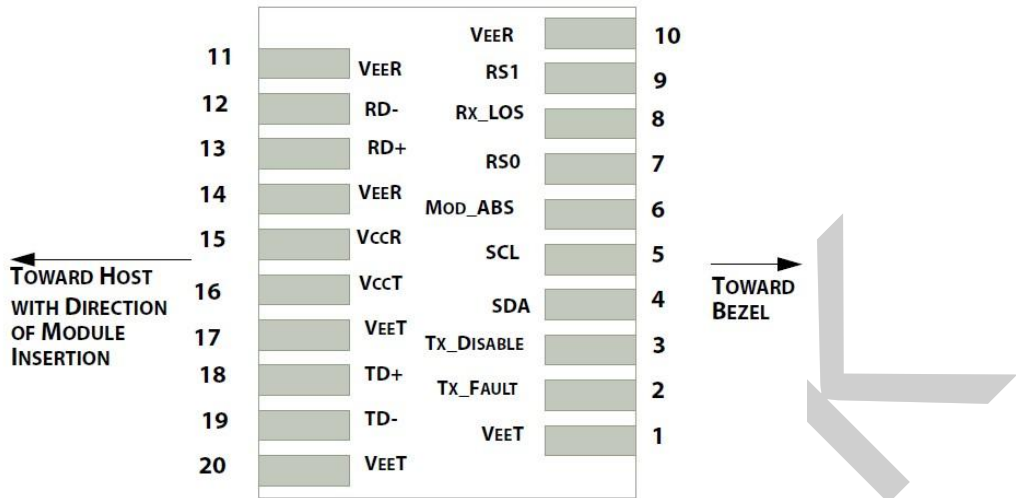

VIII.Pin Definitions

PIN #	Name	Function	Notes
1	VeeT	Transmitter Ground	1
2	Tx Fault	Transmitter Fault - High indicates a fault condition	2
3	Tx Disable	Transmitter Disable – High or open disables the transmitter	
4	SDL	2-wire Serial Interface Data Line (MOD-DEF2)	3
5	SCL	2-wire Serial Interface Clock (MOD-DEF1)	3
6	MOD-ABS	Module Absent, connected to VeeT or VeeR in the module	
7	RS0	Rate Select 0	5
8	RX_LOS	Receiver Loss of Signal(LVTTL-O). Logic 0 indicates normal operation	4
9	RS1	Rate Select 1	1
10	VeeR	Receiver Ground	1
11	VeeR	Receiver Ground	1
12	RD-	Inverse Received Data out (CML-O), AC Coupled	
13	RD+	Receiver Non-inverted DATA out. AC Coupled	
14	VeeR	Receiver Ground	1
15	VccR	Receiver Power Supply	
16	VccT	Transmitter Power Supply	
17	VeeT	Transmitter Ground	1
18	TD+	Transmitter Non-Inverted DATA in. AC Coupled.	
19	TD-	Transmitter Inverted DATA in. AC Coupled.	
20	VeeT	Transmitter Ground	1

Notes:

1. Module ground pins GND are isolated from the module case.
2. Tx_Fault is an open collector/drain output, which should be pulled up with a 4.7k – 10k Ohms resistor on Host board.

Optical Communications Products Alliance

3. Should be pulled up with 4.7k–10kohms on host board to a voltage between 2.0V and 3.6V.
4. LOS is open collector output. Should be pulled up with 4.7k–10kohms on host board to a voltage between 2.0V and 3.6V.
5. RS0 and RS1 pins are pulled low to GND with a resistor > 30KΩ in module.

IX. Recommended Interface Circuit

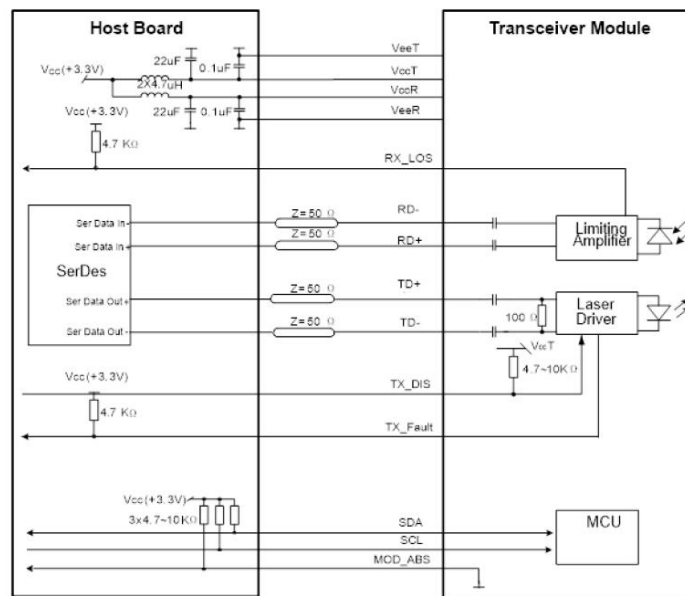

X. Mechanical Diagram

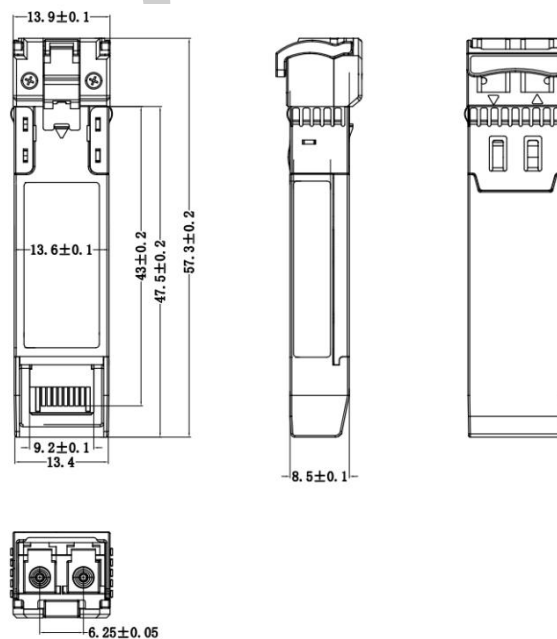

XI.Revision History

Version No.	Date	Description
1.0	April,19, 2019	Preliminary datasheet
2.0	November,8,2023	Product upgrades

Company: ETU-Link Technology Co., LTD

Address: Right side of 3rd floor, No. 102 building, Longguan expressway, Dalang street, Longhua District, Shenzhen city, GuangDong Province,China 518109

Tel: +86-755 2328 4603

Addresses and phone number also have been listed at www.etulinktechnology.com.

Please e-mail us at sales@etulinktechnology.com or call us for assistance.