

ESP3112-01D(I)

1.25Gbps SFP Optical Transceiver, 1KM Reach

PRODUCT FEATURES

- **Data-rate of 1.25Gbps operation**
- **1310nm FP laser and PIN photo detector for 1KM transmission with MMF**
- **Compliant with SFP MSA and SFF-8472 with duplex LC receptacle**
- **Digital Diagnostic Monitoring:**
- **Internal Calibration or External Calibration**
- **Compatible with SONET OC-24-LR-1**
- **Compatible with RoHS**
- **+3.3V single power supply**
- **Operating case temperature:**
 - Standard : 0 to +70°C**
 - Extended : -20 to +85°C**
 - Industrial : -40 to +85°**

APPLICATIONS

- **Gigabit Ethernet**
- **Fiber Channel**
- **Switch to Switch interface**
- **Switched backplane applications**
- **Router/Server interface**
- **Other optical transmission systems**

DESCRIPTIONS

The SFP transceivers are high performance, cost effective modules supporting data-rate of 1.25Gbps and 1KM transmission distance with MMF.

The transceiver consists of three sections: a FP laser transmitter, a PIN photodiode integrated with a trans-impedance preamplifier (TIA) and MCU control unit. All modules satisfy class I laser safety requirements. The transceivers are compatible with SFP Multi-Source Agreement (MSA) and SFF-8472. For further information, please refer to SFP MSA.

Module Block Diagram

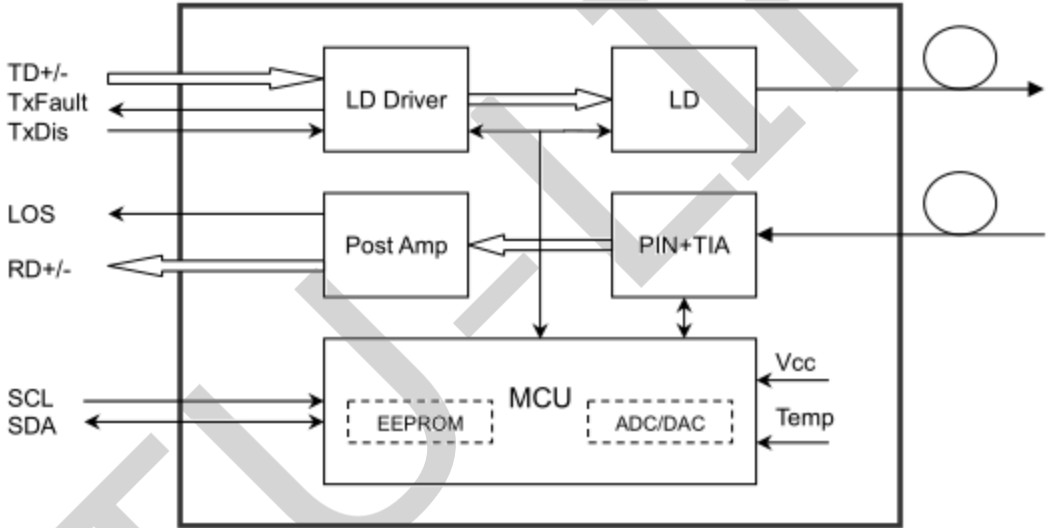

Ordering Information

Part No.	Data Rate(optical)	Laser	Fiber Type	Distance	Optical Interface	Temp	DDMI	Latch Color
ESP3112-1D	1.25Gbps	FP	MMF	1KM	LC	0~70℃	Y	Black
ESP3112-1DE	1.25Gbps	FP	MMF	1KM	LC	-20~85℃	Y	Black
ESP3112-1DI	1.25Gbps	FP	MMF	1KM	LC	-40~85℃	Y	Black

Absolute Maximum Ratings

Parameter	Symbol	Min	Typ	Max	Unit	Ref.
Maximum Supply Voltage	Vcc	-0.5		4.7	V	
Storage Temperature	TS	-40		85	°C	
Case Operating Temperature	TOP	0		70	°C	

Recommended Operating Conditions

Parameter	Symbol	Min.	Typical	Max.	Unit	Notes
Case Operating Temperature	Top	0	-	70	°C	Commercial
		-40		85		Industrial
Power Supply Voltage	Vcc	3.13	3.3	3.47	V	
Transmission Distance	TD	-	-	1	km	Over MMF

Electrical Characteristics

Parameter	Symbol	Min	Typ	Max	Unit	Ref.
Supply Voltage	Vcc	3.15	3.3	3.6	V	
Supply Current	Icc			303	mA	
Transmitter						
Input differential impedance	Rin		100		Ω	1
Single ended data input swing	Vin,pp	250		1200	mV	
Transmit Disable Voltage	VD	Vcc-1.3		Vcc	V	
Transmit Enable Voltage	VEN	Vee		Vee+ 0.8	V	2
Transmit Disable Assert Time				10	us	
Receiver						
Single ended data output swing	Vout,pp	250		800	mV	3
Data output rise time	tr		100	175	ps	4
Data output fall time	tf		100	175	ps	4
LOS Fault	VLOS fault	Vcc-0.5		VccHOST	V	5
LOS Normal	VLOS norm	Vee		Vee+0.5	V	5
Power Supply Rejection	PSR	100			mVpp	6

Notes:

1. Connected directly to TX data input pins. AC coupled thereafter.
2. Or open circuit.
3. Into 100 ohms differential termination.
4. 20 – 80 %
5. Loss of Signal is LVTTTL. Logic 0 indicates normal operation; logic 1 indicates no signal detected.
6. Receiver sensitivity is compliant with power supply sinusoidal modulation of 20 Hz to 1.5 MHz up to specified value applied through the recommended power supply filtering network.

Optical and Characteristics

Parameter	Symbol	Min	Typ	Max	Unit	Ref.
Transmitter						
Output Opt. Pwr (End of Life)	POUT	-9		-3.0	dBm	1
Optical Wavelength	λ	1270	1310	1360	nm	
Wavelength Temperature Dependence			0.08	0.125	nm/°C	
Spectral Width (-20dB)	σ			3.0	nm	
Optical Extinction Ratio	ER	10			dB	
Sidemode Suppression ratio	SSRmin	30			dB	
Optical Rise/Fall Time	tr/ tf		100	160	ps	
RIN	RIN			-120	dB/Hz	
Transmitter Jitter (peak to peak)				100	ps	
Receiver						
Average Rx Sensitivity @ Gigabit Ethernet	RSENS3			-20.0	dBm	2
Maximum Input Power	PMAX	-3.0			dBm	
Optical Center Wavelength	λ_C	1260	1310	1620	nm	
LOS De -Assert	LOSD			-22	dBm	
LOS Assert	LOSA	-40			dBm	
LOS Hysteresis			1.0		dB	
Receiver Jitter Generation @1.25Gbps				160	ps	3

Notes:

1. Class 1 Laser Safety per FDA/CDRH and IEC-825-1 regulations.
2. with worst-case extinction ratio. Measured with a PRBS 2⁷-1 test pattern, @1.25Gb/s, BER<10⁻¹²
3. Jitter added by receiver (peak to peak). Measured at -18.0dBm average Rx sensitivity, PRBS 2⁷-1 test pattern.

Digital Diagnostics

Parameter	Range	Accuracy	Unit	Calibration
Temperature	-40 to 85	±3	°C	Internal
Voltage	0 to Vcc	±3%	V	Internal
Tx Bias Current	0 to 100	±10%	mA	Internal
Tx Output Power	-9 to -3	±3	dB	Internal
Rx Input Power	-20 to -3	±3	dB	Internal

Pin Diagram

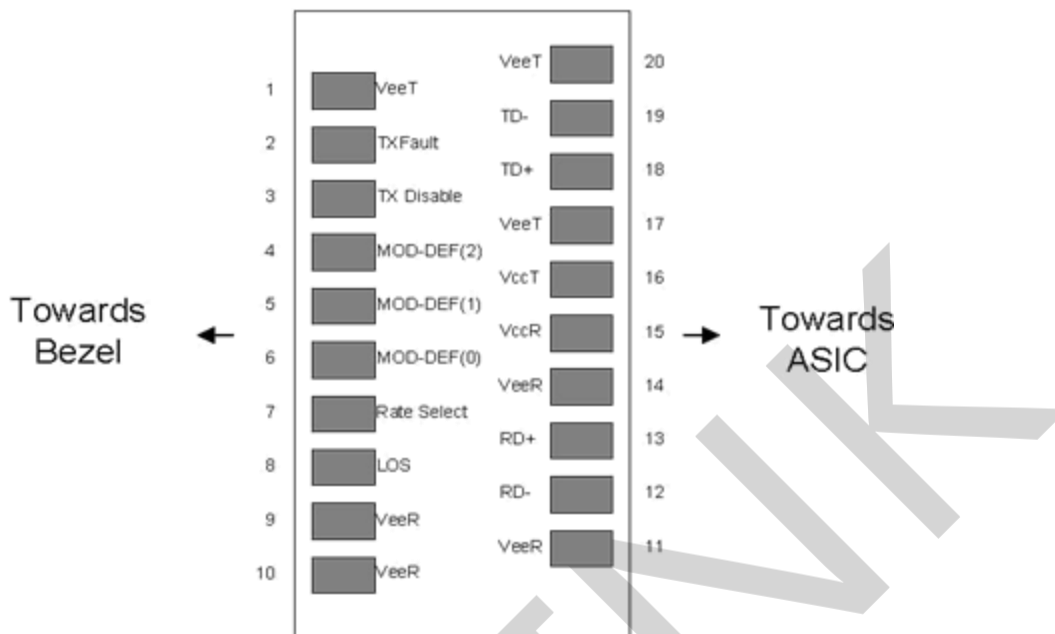

Pin Definitions

Pin	Symbol	Name/Description	Ref.
1	V_{EET}	Transmitter Ground (Common with Receiver Ground)	1
2	T_{FAULT}	Transmitter Fault.	2
3	T_{DIS}	Transmitter Disable. Laser output disabled on high or open.	3
4	MOD_DEF(2)	Module Definition 2. Data line for Serial ID.	4
5	MOD_DEF(1)	Module Definition 1. Clock line for Serial ID.	4
6	MOD_DEF(0)	Module Definition 0. Grounded within the module.	4
7	Rate Select	No connection required	
8	LOS	Loss of Signal indication. Logic 0 indicates normal operation.	5
9	V_{EER}	Receiver Ground (Common with Transmitter Ground)	1
10	V_{EER}	Receiver Ground (Common with Transmitter Ground)	1
11	V_{EER}	Receiver Ground (Common with Transmitter Ground)	1
12	RD-	Receiver Inverted DATA out. AC Coupled	
13	RD+	Receiver Non-inverted DATA out. AC Coupled	
14	V_{EER}	Receiver Ground (Common with Transmitter Ground)	1
15	V_{CCR}	Receiver Power Supply	
16	V_{CCT}	Transmitter Power Supply	
17	V_{EET}	Transmitter Ground (Common with Receiver Ground)	1
18	TD+	Transmitter Non-Inverted DATA in. AC Coupled.	
19	TD-	Transmitter Inverted DATA in. AC Coupled.	
20	V_{EET}	Transmitter Ground (Common with Receiver Ground)	1

Notes:

1. Circuit ground is internally isolated from chassis ground.
2. T_{FAULT} is an open collector/drain output, which should be pulled up with a 4.7k – 10k Ohms resistor on the host board if intended for use. Pull up voltage should be between 2.0V to $V_{cc} + 0.3V$. A high output indicates a transmitter fault caused by either the TX bias current or the TX output power exceeding the preset alarm thresholds. A low output indicates normal operation. In the low state, the output is pulled to <0.8V.
3. Laser output disabled on $T_{DIS} > 2.0V$ or open, enabled on $T_{DIS} < 0.8V$.
4. Should be pulled up with 4.7k- 10kohms on host board to a voltage between 2.0V and 3.6V. MOD_DEF(0) pulls line low to indicate module is plugged in.
5. LOS is open collector output. Should be pulled up with 4.7k – 10 kohms on host board to a voltage between 2.0V and 3.6V. Logic 0 indicates normal operation; logic 1 indicates loss of signal.

Recommended Interface Circuit

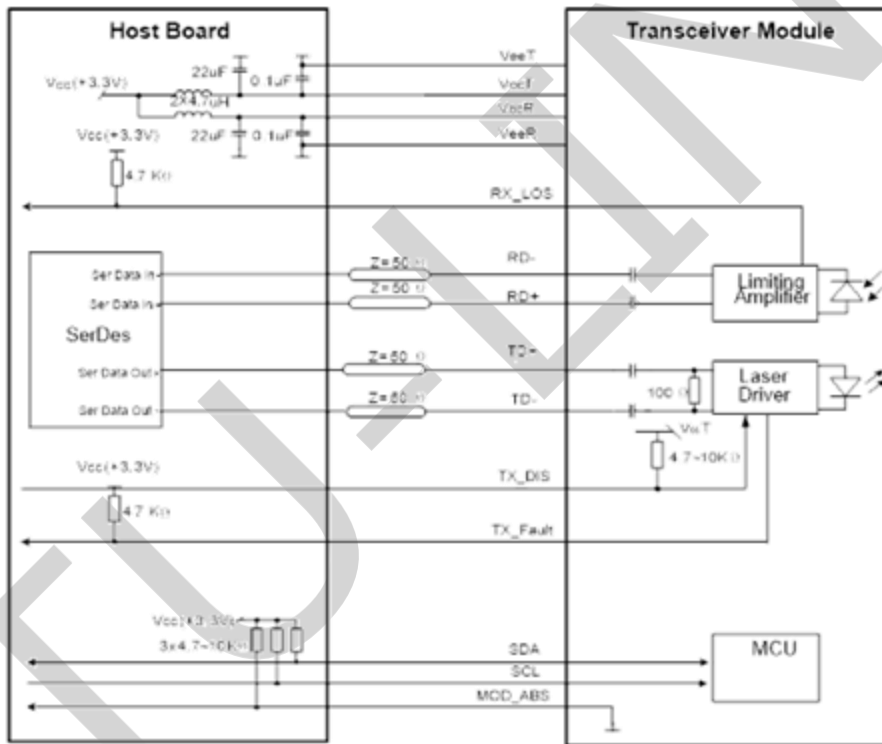

Mechanical Diagram

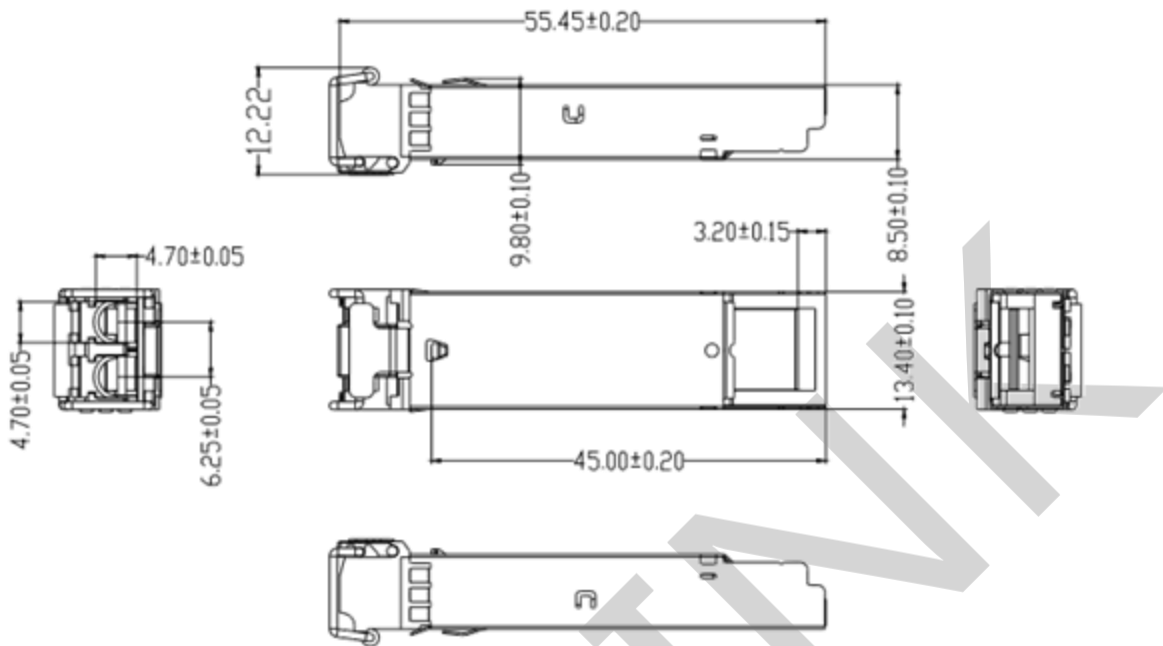

Revision History

Version No.	Date	Description
1.0	February 12, 2016	Preliminary datasheet
2.0	September 22, 2023	Product upgrades
3.0	July 23, 2024	Format change

Company: ETU-Link Technology Co., LTD

Production base: Right side of 3rd floor, No. 102 building, Longguan expressway, Dalang street, Longhua District, Shenzhen city, Guangdong Province, China 518109

R&D base: Floor 4, Building 4, Nanshan Yungu Phase LI, Taoyuan Community, Xili Street, Nanshan District, Shenzhen

Tel: +86-755 2328 4603

Addresses and phone number also have been listed at www.etulinktechnology.com.

Please e-mail us at sales@etulinktechnology.com or call us for assistance.