

ESDxx03-80D(I)

155M DWDM SFP Optical Transceiver 80KM Reach

Features

- Up to 155M data links
- DWDM EML laser transmitter and PIN photo-detector
- 100 GHz ITU channel spacing with integrated wavelength locker
- Up to 80km on 9/125μm SMF
- Hot-pluggable SFP footprint
- Duplex LC/UPC type pluggable optical interface
- Low power dissipation
- RoHS-10 compliant and lead-free
- Support Digital Diagnostic Monitoring interface
- Single +3.3V power supply
- Compliant with SFF-8472
- Metal enclosure, for lower EMI
- Meet ESD requirements, resist 8KV direct contact voltage
- Case operating temperature:
Commercial : 0°C to 70°C
Extended: -10 ~ +80°C
Industrial: -40 ~ +85°C



Applications

- SONET/SDH networks
- Gigabit Ethernet
- C Band DWDM networks
- Fiber Channel
- Other Optical Links

Description

The transceivers include and PIN photo-detector diode and temperature stabilized DWDM EML transmitter. Digital diagnostic functions are available via an I2C. This module is designed for single mode fiber and operates at a nominal wavelength of 100GHz ITU Grid, C Band DWDM wavelength. Digital diagnostics functions are available via a 2-wire serial interface, as specified in SFF-8472.

The optical output can be disabled by a TTL logic high-level input of Tx Disable, and the system also can disable the module via I2C. Tx Fault is provided to indicate that degradation of the laser. Loss of signal (LOS) output is provided to indicate the loss of an input optical signal of receiver or the link status with partner. The system can also get the LOS (or Link)/Disable/Fault information via I2C register access.

Module Block Diagram

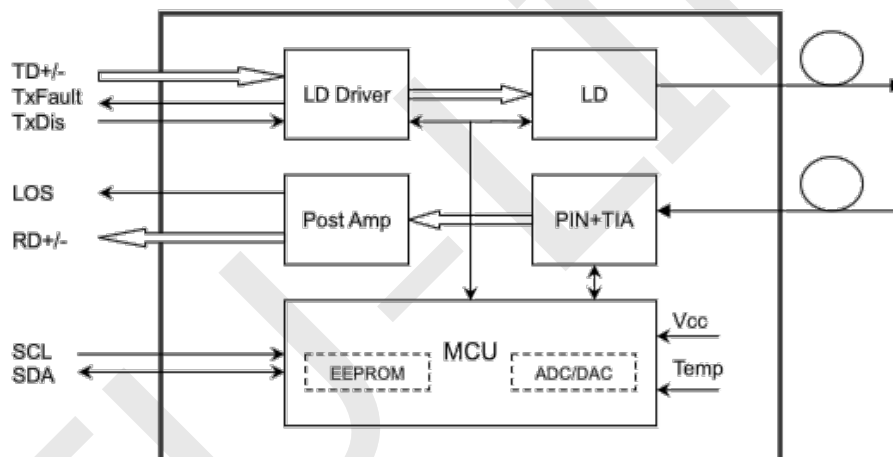

Ordering Information

Part No.	Data Rate(optical)	Laser	Fiber Type	Distance	Optical Interface	Temp	DDMI
ESDxx03-80D	155M	EML	SMF	80km	LC	0~70°C	Y
ESDxx03-80DE	155M	EML	SMF	80km	LC	-10~80°C	Y
ESDxx03-80DI	155M	EML	SMF	80km	LC	-40~85°C	Y

Wavelength Selection: C-band λ_c Wavelength Guide Pin Descriptions

Channel	Wavelength (nm)	Frequency (THZ)	Channel	Wavelength (nm)	Frequency (THZ)
C17	1563.86	191.70	C39	1546.12	193.90
C18	1563.05	191.80	C40	1545.32	194.00
C19	1562.23	191.90	C41	1544.53	194.10
C20	1561.42	192.00	C42	1543.73	194.20
C21	1560.61	192.10	C43	1542.94	194.30
C22	1559.79	192.20	C44	1542.14	194.40
C23	1558.98	192.30	C45	1541.35	194.50
C24	1558.17	192.40	C46	1540.56	194.60
C25	1557.36	192.50	C47	1539.77	194.70
C26	1556.55	192.60	C48	1538.98	194.80
C27	1555.75	192.70	C49	1538.19	194.90
C28	1554.94	192.80	C50	1537.40	195.00
C29	1554.13	192.90	C51	1536.61	195.10
C30	1553.33	193.00	C52	1535.82	195.20
C31	1552.52	193.10	C53	1535.04	195.30
C32	1551.72	193.20	C54	1534.25	195.40
C33	1550.92	193.30	C55	1533.47	195.50
C34	1550.12	193.40	C56	1532.68	195.60
C35	1549.32	193.50	C57	1531.90	195.70
C36	1548.51	193.60	C58	1531.12	195.80
C37	1547.72	193.70	C59	1530.33	195.90
C38	1546.92	193.80	C60	1529.55	196.00
Non-ITU	Peak wavelength between 1528.77nm-1563.86		C61	1528.77	196.10

Absolute Maximum Ratings

It has to be noted that the operation in excess of any individual absolute maximum ratings might cause permanent damage to this module.

Parameter	Symbol	Min	Max	Unit	Notes
Storage Temperature	T_s	-40	85	°C	
Operating Case Temperature	T_{case}	See order Information		°C	
Power Supply Voltage	V_{CC}	-0.5	3.6	V	
Relative Humidity (non-condensation)	RH	5	95	%	
Damage Threshold	TH_d	5		dBm	

Recommended Operating Conditions and Power Supply Requirements

Parameter	Symbol	Min	Typical	Max	Unit	Notes
Operating Case Temperature	T_{OP}	0		70	°C	Commercial
		-40		85		Industrial
Power Supply Voltage	V_{CC}	3.135	3.3	3.465	V	
Power Supply Current	ICC			500	mA	
Data Rate			155		Mb/s	
Control Input Voltage High		2		V_{CC}	V	
Control Input Voltage Low		0		0.8	V	
Link Distance (SMF)	D			80	km	9/125um

Specification of Transmitter Electrical Characteristics

The following electrical characteristics are defined over the Recommended Operating Environment unless otherwise specified.

Parameter	Symbol	Min.	Typical	Max	Unit	Notes
Transmitter						
Single-ended Input Voltage	V_{CC}	-0.3		4.0	V	

Tolerance						
Differential Input Voltage Swing	V _{in,pp}	200		2400	mVpp	
Differential Input Impedance	Z _{in}	90	100	110	Ohm	
Transmit Disable Assert Time				5	us	
Transmit Disable Voltage	V _{dis}	V _{cc} -1.3		V _{cc}	V	
Transmit Enable Voltage	V _{en}	V _{ee} -0.3		0.8	V	
Receiver						
Differential Output Voltage Swing	V _{out,pp}	500		900	mVpp	
Differential Output Impedance	Z _{out}	90	100	110	Ohm	
Data output rise/fall time	Tr/Tf		100		ps	20% to 80%
LOS Assert Voltage	V _{losH}	V _{cc} -1.3		V _{cc}	V	
LOS De-assert Voltage	V _{losL}	V _{ee} -0.3		0.8	V	

Optical Characteristics

The following optical characteristics are defined over the Recommended Operating Environment unless otherwise specified.

Parameter	Symbol	Min.	Typical	Max	Unit	Notes
Transmitter						
Optical Wavelength	λ_c	$\lambda_c - 0.1$		$\lambda_c + 0.1$	nm	1
Center Wavelength Spacing			100		GHz	
Spectrum Bandwidth(RMS)	σ			1	nm	
Side Mode Suppression Ratio	SMSR	30			dB	
Average Optical Power	P _{AVG}	0		4	dBm	2
Optical Extinction Ratio	ER	9			dB	
Transmitter OFF Output Power	P _{Off}			-45	dBm	
Transmitter Eye Mask	Compliant with 802.3z(class 1 laser safety)					
Receiver						
Center Wavelength	λ_c	1270		1610	nm	

Receiver Sensitivity (Average Power)	Sen.				-26	dBm	3
Input Saturation Power (overload)	Psat	-3				dBm	
LOS Assert	LOSA	-36				dB	4
LOS De-assert	LOSD				-27	dBm	4
LOS Hysteresis	LOSH	0.5	2	6		dBm	

Notes:

1. λc refer to wavelength selection, and corresponds to approximately 0.8 nm
2. Measure at 2^7-1 NRZ PRBS pattern
3. Measured with Light source 1563.86~1528.77nm, ER=9dB; BER $\leq 10^{-12}$ @PRBS= 2^7-1 NRZ
4. When LOS de-asserted, the RX data+/- output is High-level (fixed).

Digital Diagnostic Functions

The following digital diagnostic characteristics are defined over the Recommended Operating Environment unless otherwise specified. It is compliant to SFF-8472 Rev10.2 with internal calibration mode. For external calibration mode please contact our sales staff.

Parameter	Symbol	Min.	Max	Unit	Notes
Temperature monitor absolute error	DMI_Temp	-3	3	degC	Over operating temp
Supply voltage monitor absolute error	DMI_VCC	-0.15	0.15	V	Full operating range
RX power monitor absolute error	DMI_RX	-3	3	dB	
Bias current monitor	DMI_bias	-10%	10%	mA	
TX power monitor absolute error	DMI_TX	-3	3	dB	

Pin Assignment and Pin Description

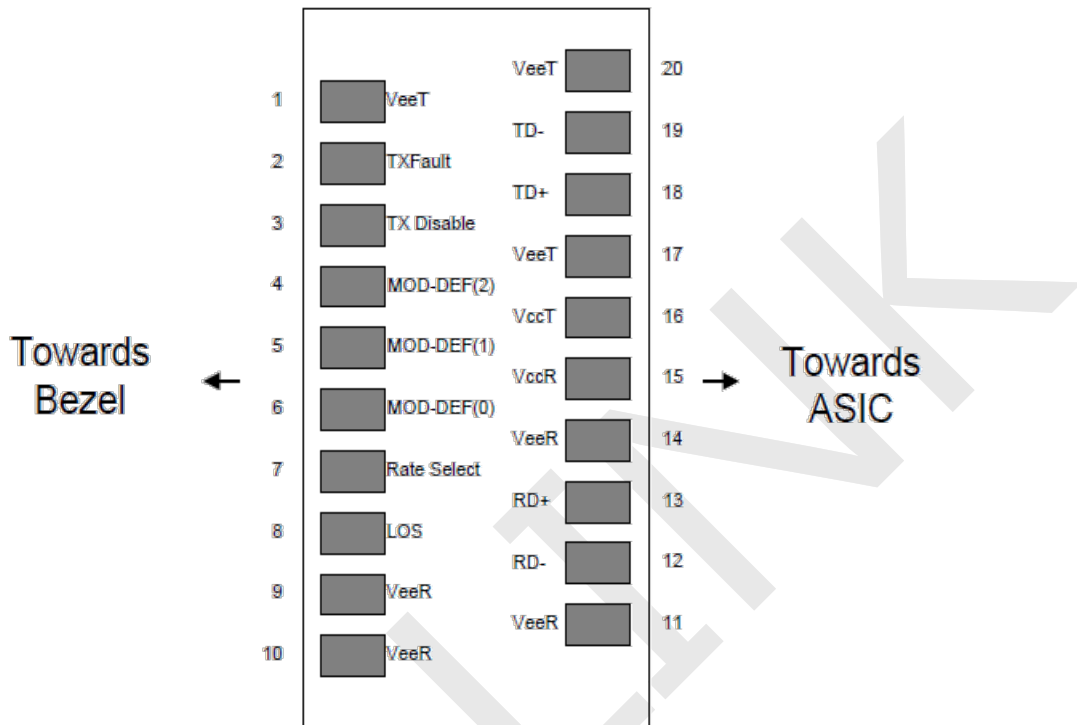

Figure1. Diagram of host board connector block pin numbers and names

PIN	Name	Name/Description	Notes
1	VEET	Transmitter Ground (Common with Receiver Ground)	1
2	TXFAULT	Transmitter Fault.	
3	TXDIS	Transmitter Disable. Laser output disabled on high or open.	2
4	MOD_DEF(2)	Module Definition 2. Data line for Serial ID.	3
5	MOD_DEF(1)	Module Definition 1. Clock line for Serial ID.	3
6	MOD_DEF(0)	Module Definition 0. Grounded within the module.	3
7	Rate Select	No connection required	4
8	LOS	Loss of Signal indication. Logic 0 indicates normal operation.	5
9	VEER	Receiver Ground (Common with Transmitter Ground)	1
10	VEER	Receiver Ground (Common with Transmitter Ground)	1
11	VEER	Receiver Ground (Common with Transmitter Ground)	1
12	RD-	Receiver Inverted DATA out. AC Coupled	

13	RD+	Receiver Non-inverted DATA out. AC Coupled	
14	VEER	Receiver Ground (Common with Transmitter Ground)	1
15	VCCR	Receiver Power Supply	
16	VCCT	Transmitter Power Supply	
17	VEET	Transmitter Ground (Common with Receiver Ground)	1
18	TD+	Transmitter Non-Inverted DATA in. AC Coupled.	
19	TD-	Transmitter Inverted DATA in. AC Coupled.	
20	VEET	Transmitter Ground (Common with Receiver Ground)	1

Notes:

1. Circuit ground is internally isolated from chassis ground.
2. Laser output disabled on TDIS >2.0V or open, enabled on TDIS <0.8V.
3. Should be pulled up with 4.7k-10k ohms on host board to a voltage between 2.0V and 3.6V. MOD_DEF (0) pulls line low to indicate module is plugged in.
4. This is an optional input used to control the receiver bandwidth for compatibility with multiple data rates (most likely Fiber Channel 1x and 2x Rates). If implemented, the input will be internally pulled down with > 30kΩ resistor. The input states are:
 - 1) Low (0 – 0.8V): Reduced Bandwidth
 - 2) (>0.8, < 2.0V): Undefined
 - 3) High (2.0 – 3.465V): Full Bandwidth
 - 4) Open: Reduced Bandwidth
5. LOS is open collector output should be pulled up with 4.7k-10k ohms on host board to a voltage between 2.0V and 3.6V. Logic 0 indicates normal operation; logic 1 indicates loss of signal.

Recommended Interface Circuit

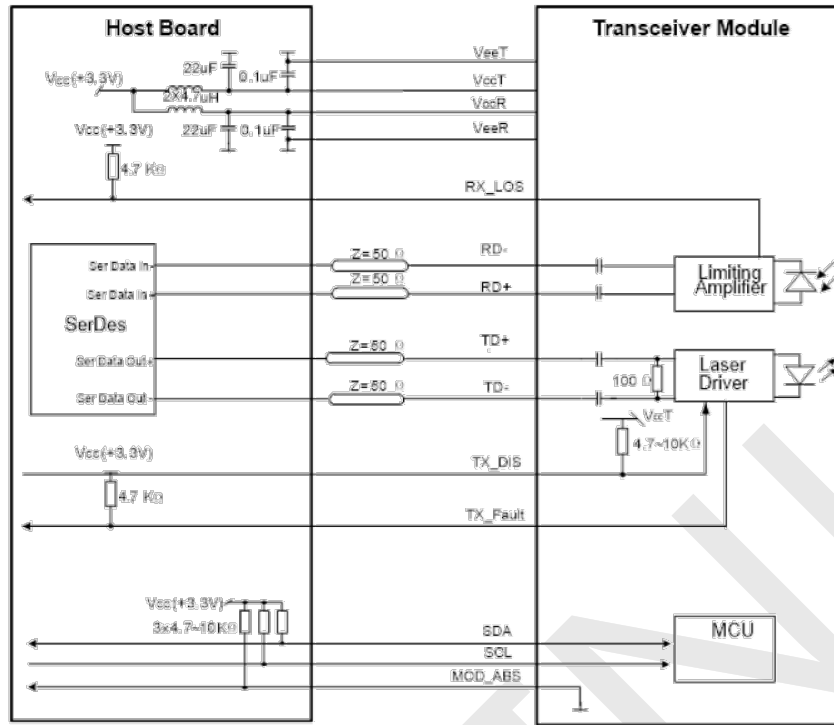

Mechanical Dimensions

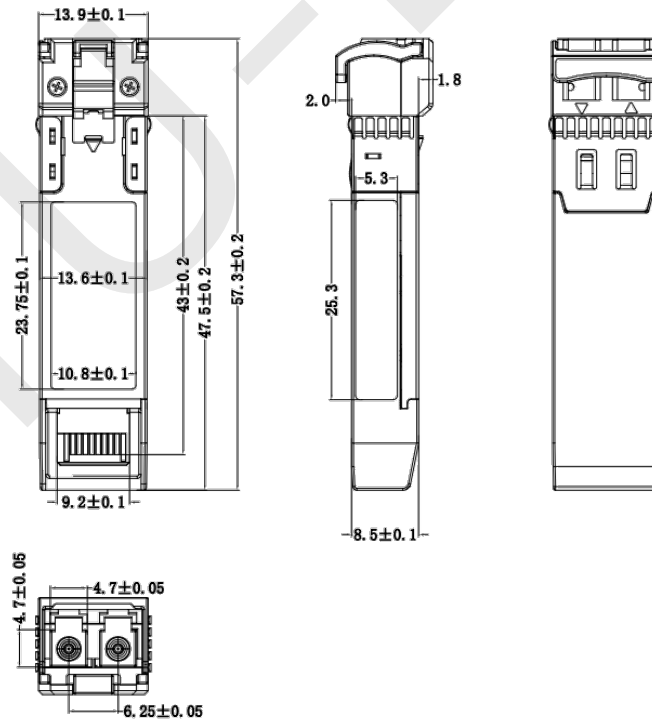

Revision History

Version No.	Date	Description
1.0	February 12, 2015	Preliminary datasheet
2.0	October 11, 2021	Product upgrades
3.0	July 26, 2024	Format change

Company: ETU-Link Technology Co., LTD

Production base: Right side of 3rd floor, No. 102 building, Longguan expressway, Dalang street, Longhua District, Shenzhen city, Guangdong Province, China 518109

R&D base: Floor 4, Building 4, Nanshan Yungu Phase LI, Taoyuan Community, Xili Street, Nanshan District, Shenzhen

Tel: +86-755 2328 4603

Addresses and phone number also have been listed at www.etulinktechnology.com.

Please e-mail us at sales@etulinktechnology.com or call us for assistance.