

ESP312X-10D(I)

25Gb/s SFP28 10km DDM Transceiver

PRODUCT FEATURES

- Support data rate up to 25.78125Gb/s
- Hot-Pluggable SFP Footprint and Single LC Connector
- Up to 10km reach for G.652 SMF
- 1310nm DFB laser and PIN receiver
- Temperature Range:
 - Commercial:0°C ~70°C
 - Industrial: -40°C ~85°C
- Power consumption
 - Commercial:1.0W
 - Industrial:1.2W
- RoHS 6 compliance
- Compliant to IEEE 802.3cc, SFF-8472 and SFF-8419
- Complies with EU Directive 2015/863/EU



APPLICATIONS

- 25GBASE-LR
- CPRI option 10

DESCRIPTIONS

The SFP28 transceivers are high performance, cost effective modules supporting data rate of 25.78Gbps and 10KM transmission distance with SMF.

The transceiver consists of three sections: a DFB laser transmitter, a PIN photodiode integrated with a trans-impedance preamplifier (TIA) and MCU control unit. All modules satisfy class I laser safety requirements.

The transceivers are compatible with SFP Multi-Source Agreement and SFF-8472 digital diagnostics functions.

Module Block Diagram

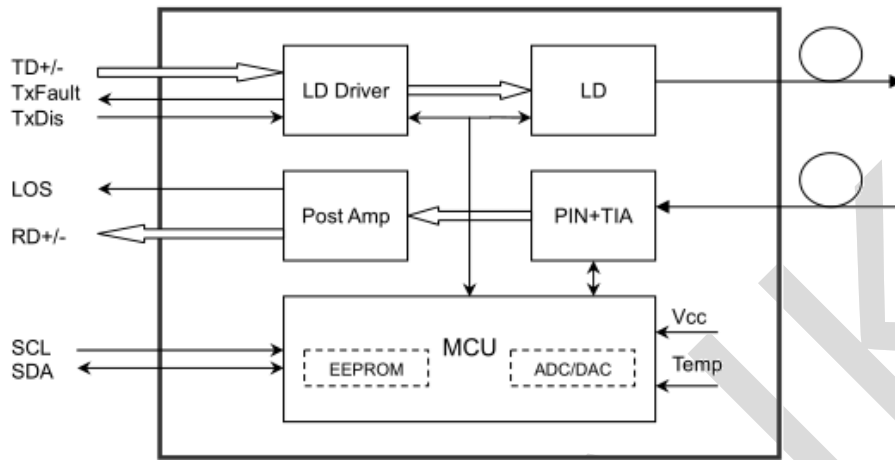

Ordering Information

Part No.	Data Rate(optical)	Laser	Fiber Type	Distance	Optical Interface	Temp	DDMI	Latch Color
ESP312X-10D	25.78Gbps	DFB	SM	10KM	LC	0~70°C	Y	Blue
ESP312X-10DI	25.78Gbps	DFB	SM	10KM	LC	-40~85°C	Y	Blue

Absolute Maximum Ratings

Parameter	Symbol	Min.	Typical	Max.	Unit	Notes
Storage Temperature	T _{stg}	-40		+85	°C	
Case Operating Temperature(Commercial)	T _o	0		70	°C	
Case Operating Temperature (Industrial)	T _o	-40		85	°C	
Relative Humidity - Storage	R _{HS}	5		95	%	
Relative Humidity - Operating	R _{HO}	5		85	%	
DC Supply Voltage	V _{cc}	0		3.6	V	

Recommended Operating Conditions

Parameter	Symbol	Min.	Typical	Max.	Unit	Notes
Case Operating Temperature	Top	0	-	70	°C	Commercial
		-40		85		Industrial
Power Supply Voltage	V _{cc}	3.13	3.3	3.47	V	
Transmission Distance	TD	-	-	10	km	Over SMF

Electrical Characteristics

High-Speed Signal: Compliant to CEI-25G-VSR

Low-Speed Signal: Compliant to SFF-8419

Parameter	Symbol	Min.	Typical	Max.	Unit	Notes	
Transmitter (Module Input)							
Differential Input Resistance	R_R _{din}	90	100	110	Ω		
Input Differential Voltage	R_V _{diff}	-	-	900	mVpp		
Tx_Disable	Normal Operation	V _{IL}	-0.3	-	0.8	V	
	Laser Disable	V _{IH}	2.0	-	V _{CC} +0.3	V	
Receiver (Module Output)							
Differential Resistance	T_R _d	90	100	110	Ohm		
Output Differential Voltage	T_V _{diff}	-	-	900	mVpp		
Differential Termination Resistance Mismatch	T_R _d m	-	-	10	%		
Rx Ios	Normal Operation	V _{OL}	-0.3	-	0.4	V	
	Loss Signal	V _{OH}	2	-	V _{CC} HOST	V	

Optical and Characteristics

Parameter	Symbol	Min.	Typical	Max.	Unit	Notes
Transmitter						
Optical Modulation Amplitude(OMA)	POMA	-4		2.2	dBm	1
Average Output Power	POUT	-7		2	dBm	
Average Output Power(Laser Off)	POFF			-30	dBm	
Wavelength	λ	1295		1325	nm	
Spectrum Bandwidth @ -20dB	Δλ			1	nm	
Side mode suppression ratio(SMSR)	SMSR	30			dB	
Extinction ratio	ER	3.5			dB	
Transmitter and dispersion penalty (TDP)				2.7	dB	
RIN ₂₀ OMA	RIN			-130	dB/Hz	
Receiver						
Wavelength	λ	1295		1325	nm	
Received Sensitivity(OMA)	P _{SEN-OMA}			-13.3	dBm	2
Stressed receiver sensitivity (OMA)	R _{SEN-OMA-stress}	-	-	-9.5	dBm	2
Optical Power Overload	P _{IN} (SAT)	2			dBm	
Damage threshold		3			dBm	3
Receiver Reflectance	RFL			-26	dB	

Rx_LOS of Signal Assert	P_A	-30			dBm	
Rx_LOS of Signal De-assert	P_D			-17	dBm	
Rx_LOS of Signal Hysteresis	P_{Hy}	0.5		5	dB	
Optical Return Loss Tolerance	ORLT	20			dB	

Notes:

1. The optical power is launched into SMF
2. Test pattern: PRBS31. BER5×10^{-5};
3. The receiver shall be able to tolerate, without damage, continuous exposure to an optical input signal having this average power level. The receiver does not have to operate correctly at this input power.

Digital Diagnostics

Parameter	Range	Accuracy	Unit	Calibration
Temperature	0 to +70	$\pm 3^\circ\text{C}$	$^\circ\text{C}$	Internal
Voltage	3.0 to 3.6	$\pm 3\%$	V	Internal
Bias Current	0 to 100	$\pm 10\%$	mA	Internal
TX Power	-7 to 2	$\pm 3\text{dB}$	dBm	Internal
RX Power	-14 to +2	$\pm 3\text{dB}$	dBm	Internal

Communication Interface Timing Characteristics

Parameter	Symbol	Min.	Typical	Max.	Unit	Notes
Tx Disable Negate Time	t_{on}			2	ms	
Tx Disable Assert Time	t_{off}			100	μs	
Time To Initialize, including Reset of Tx Fault	t_{init}			300	ms	
Tx Fault Assert Time	t_{fault}			100	μs	
Tx Disable To Reset	t_{reset}	10			μs	
LOS Assert Time	t_{loss_on}			100	μs	
LOS De-assert Time	t_{loss_off}			100	μs	
Serial ID Clock Rate	f_{serial_clock}		100	400	KHz	
MOD_DEF (0:2)-High	V_H	2		V_{cc}	V	
MOD_DEF (0:2)-Low	V_L			0.8	V	

Pin Diagram

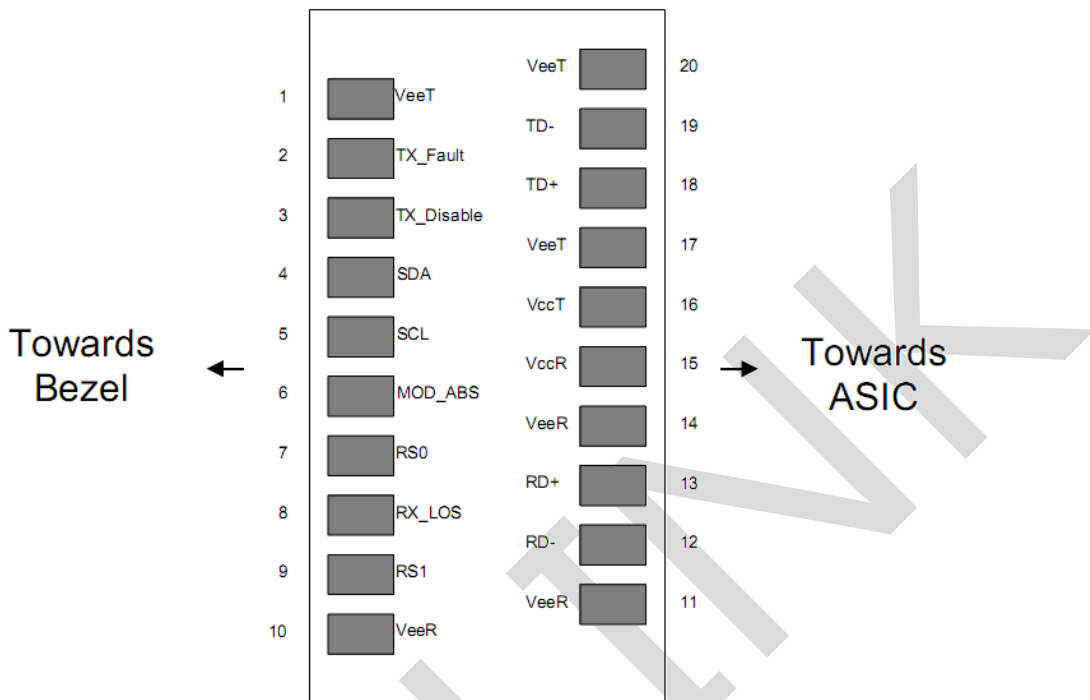

Pin Definitions

PIN #	Name	Function	Notes
1	VEET	Transmitter Ground	
2	TX FAULT	Transmitter Fault Indication	Note 1
3	TX DISABLE	Transmitter Disable	Note 2
4	SDA	SDA Serial Data Signal	
5	SCL	SCL Serial Clock Signal	
6	MOD_ABS	Module Absent. Grounded within the module	
7	RS0	Not Connected	
8	LOS	Loss of Signal	Note 3
9	RS1	Not Connected	
10	VEER	Receiver ground	
11	VEER	Receiver ground	
12	RD-	Inv. Received Data Out	Note 4
13	RD+	Received Data Out	Note 4
14	VEER	Receiver ground	
15	VCCR	Receiver Power Supply	
16	VCCT	Transmitter Power Supply	
17	VEET	Transmitter Ground	
18	TD+	Transmit Data In	Note 5

19	TD-	Inv. Transmit Data In	Note 5
20	V _{EET}	Transmitter Ground	

Notes:

1. TX Fault is an open collector output, which should be pulled up with a 4.7k~10kΩ resistor on the host board to a voltage between 2.0V and V_{cc}+0.3V. Logic 0 indicates normal operation; Logic 1 indicates a laser fault of some kind. In the low state, the output will be pulled to less than 0.8V.
2. Laser output disabled on TDIS >2.0V or open, enabled on TDIS <0.8V.
3. LOS is open collector output. Should be pulled up with 4.7k~10kΩ on host board to a voltage between 2.0V and 3.6V. Logic 0 indicates normal operation; logic 1 indicates loss of signal.
4. RD-/+ : These are the differential receiver outputs. They are internally AC-coupled 100 differential lines which should be terminated with 100Ω (differential) at the user SERDES.
5. TD-/+ : These are the differential transmitter inputs. They are internally AC-coupled, differential lines with 100Ω differential termination inside the module.

Recommended Interface Circuit

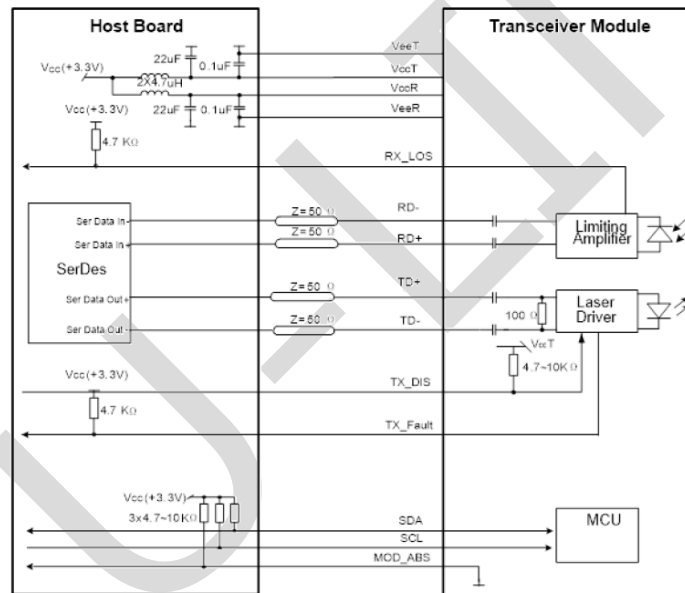

Mechanical Diagram

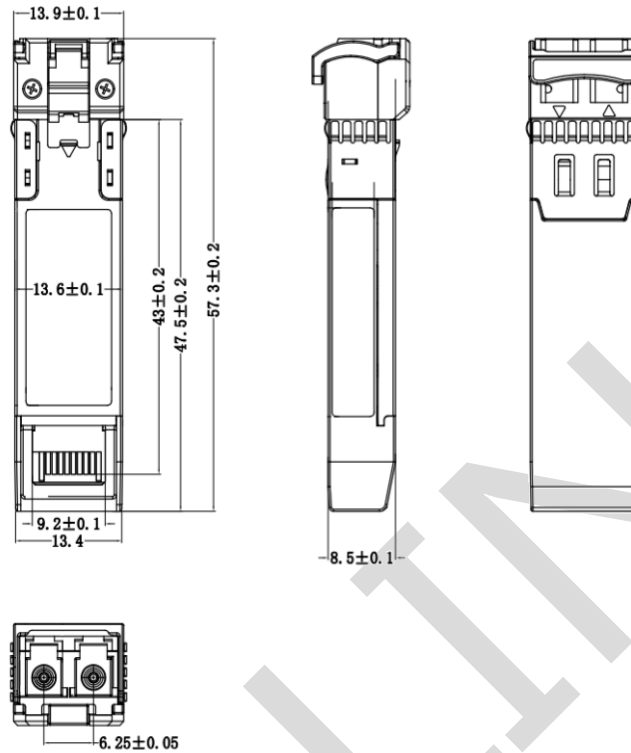

Revision History

Version No.	Date	Description
1.0	April,19, 2019	Preliminary datasheet
2.0	November,8,2023	Product upgrades
2.1	Aug 20, 2024	Format change

Company: ETU-Link Technology Co., LTD

Production base: Right side of 3rd floor, No. 102 building, Longguan expressway, Dalang street, Longhua District, Shenzhen city, Guangdong Province, China 518109

R&D base: Floor 4, Building 4, Nanshan Yungu Phase LI, Taoyuan Community, Xili Street, Nanshan District, Shenzhen

Tel: +86-755 2328 4603

Addresses and phone number also have been listed at www.etulinktechnology.com.

Please e-mail us at sales@etulinktechnology.com or call us for assistance.